

## European Technical Assessment

**ETA 19/0453**  
of 08/06/2020

### General Part

**Technical Assessment Body issuing the European Technical Assessment:**

RISE Research Institutes of Sweden AB

**Trade name of the construction product**

EJOT self-tapping screws  
EJOT PONDUS JW2-ZT-6,5xL  
EJOT PONDUS JW2-ZT-8,2xL

**Product family to which the construction product belongs**

Screws for use in timber constructions.

**Manufacturer**

EJOT Baubefestigungen GmbH  
In der Stockwiese 35  
D-57334 Bad Laasphe, Germany

**Manufacturing plant(s)**

EJOT Plant 42

**This European Technical Assessment contains**

28 pages including 5 Annexes which form an integral part of this assessment.

**This European Technical Assessment is issued in accordance with regulation (EU) No 305/2011, on the basis of**

EAD -130118-00-0603 dated October 2016, screws for use in timber constructions.

Translations of this European Technical Assessment in other languages shall fully correspond to the original issued document and should be identified as such.

Communication of this European Technical Assessment, including transmission by electronic means, shall be in full. However, partial reproduction may be made with the written consent of the issuing Technical Assessment Body. Any partial reproduction has to be identified as such.

Specific parts

## 1 Technical description of the product

EJOT PONDUS JW2-ZT-6,5xL-L1/L2-V-T30 // EJOT PONDUS JW2-ZT-8,2xL-L1/L2-V-T40  
 EJOT PONDUS JW2-ZT-6,5xL-L1/L2-R-T30 // EJOT PONDUS JW2-ZT-8,2xL-L1/L2-R-T40  
 are double-threaded, self-tapping screws. The screws are made from special carbon steel with two different types of Zinc-coating. The screws have an anti-friction coating.

The nominal outer thread diameter is 6.5 mm and 8.2 mm. The overall length of the screw is ranging from 90 mm to 330 mm (nominal dimension). Further dimensions are shown in Annex 5.

## 2 Specification of the intended use(s) in accordance with the applicable European Assessment Document (hereinafter EAD)

The performances given in Section 3 are only valid if the Pondus screws are used in compliance with the specifications and conditions given in Annex 1 and 2.

Durability is only ensured if the specifications of intended use according to Annex 1 and 2 are taken into account.

The verifications and assessment methods on which this European Technical Assessment is based lead to the assumption of a working life of the screws of at least 50 years. The indications given on the working life cannot be interpreted as a guarantee given by the producer, but are to be regarded only as a means for choosing the right products in relation to the expected economically reasonable working life of the works.

## 3 Performance of the product and references to the methods used for its assessment

### 3.1 Essential characteristics and their performance

		Characteristic	Performance
BWR 1	Mechanical resistance and stability	Dimensions	See Annex 5
		Characteristic yield moment	See Annex 2
		Bending angle	See Annex 2
		Characteristic withdrawal parameter	See Annex 2
		Characteristic head pull-through parameter	See Annex 2
		Characteristic tensile strength	See Annex 2
		Characteristic yield strength	See Annex 2
		Characteristic torsional strength	See Annex 2
		Insertion moment	See Annex 2
		Spacing, end and edge distances of the screws and minimum thickness of the wood based material	See Annex 2
		Slip modulus for mainly axially loaded screws	See Annex 2
		Durability against corrosion	See Annex 2
BWR 2	Safety in case of fire	Reaction to fire	Class A1
BWR 4	Safety in use		Same as BWR 1

#### **4 Assessment and verification of constancy of performance (hereinafter AVCP) system applied, with reference to its legal base**

According to the decision 1997/176/EC, of the European Commission, the system of assessment and verification of constancy of performance (see Annex V to the regulation (EU) No 305/2011) given in the following table apply:

<b>Product(s)</b>	<b>Intended use(s)</b>	<b>Level(s) or class(es)</b>	<b>System(s)</b>
Screws for use in timber constructions	For building works	-	3

#### **5 Technical details necessary for the implementation of the AVCP system, as provided for in the applicable EAD**

Technical details necessary for the implementation of the AVCP system are laid down in the control plan deposited at RISE.

Issued in Borås on 08.06.2020  
By RISE Research Institutes of Sweden AB

Johan Åkesson  
Certification Manager

## Annex 1 Specifications of intended use

### A.1.1 Use of the EJOT Pondus screws only for:

- Static and quasi-static loads

### A.1.2 Base materials

The screws are used for connections in load bearing timber structures between wood-based members:

- Solid timber (softwood) according to EN 14081-1<sup>1</sup>,
- Glued laminated timber (softwood) according to EN 14080<sup>2</sup>,
- Laminated veneer lumber LVL made of softwood according to EN 14374<sup>3</sup>,
- Glued solid timber according to EN 14080 or national provisions that apply at the installation site,
- Cross-laminated timber according to European Technical Assessments or national provisions that apply at the installation site.

The screws may be used for connecting the following wood-based panels to the timber members mentioned above:

- Plywood according to EN 636<sup>4</sup> and EN 13986<sup>5</sup>,
- Oriented Strand Board, OSB according to EN 300<sup>6</sup> and EN 13986,
- Particleboard according to EN 312<sup>7</sup> and EN 13986,
- Fibreboards according to EN 622-2<sup>8</sup>, EN 622-3<sup>9</sup> and EN 13986,
- Cement-bonded particle boards according to EN 634-2<sup>10</sup> and EN 13986,
- Solid-wood panels according to EN 13353<sup>11</sup> and EN 13986.

Wood-based panels shall only be arranged on the side of the screw head.

EJOT Pondus screws may be used for reinforcing of timber structures perpendicular to the grain.

<sup>1</sup> EN 14081-1:2005+A1:2011

Timber structures – Strength graded structural timber with rectangular cross section – Part 1: General requirements

<sup>2</sup> EN 14080:2013

Timber structures - Glued laminated timber and glued solid timber – Requirements

<sup>3</sup> EN 14374:2004

Timber structures - Structural laminated veneer lumber – Requirements

<sup>4</sup> EN 636:2012+A1:2015

Plywood – Specifications

<sup>5</sup> EN 13986:2004+A1:2015

Wood-based panels for use in construction - Characteristics, evaluation of conformity and marking

<sup>6</sup> EN 300:2006

Oriented strand boards (OSB) – Definition, classification and specifications

<sup>7</sup> EN 312:2010

Particleboards – Specifications

<sup>8</sup> EN 622-2:2004/AC:2005

Fibreboards – Specifications – Part 2: Requirements for hardboards

<sup>9</sup> EN 622-3:2004

Fibreboards - Specifications - Part 3: Requirements for medium boards

<sup>10</sup> EN 634-2:2007

Cement-bonded particleboards – Specifications – Part 2:  
Requirements for OPC bonded particleboards for use in dry, humid  
and external conditions

<sup>11</sup> EN 13353:2008+A1:2011

Solid wood panels (SWP) – Requirements

### **A.1.3 Use Conditions (environmental conditions)**

The corrosion protection of the EJOT Pondus screws is specified in Annex A.2.6. With regard to the use and the environmental conditions the national provisions of the place of installation apply.

### **A.1.4 Installation provisions**

EN 1995-1-1<sup>12</sup> in conjunction with the respective national annex applies for the installation.

The screws are driven into the wood-based member made of softwood without pre-drilling.

A minimum of two screws shall be used for connections in load bearing timber structures. This does not apply for special situations specified in National Annexes to EN 1995-1-1.

If the screws with an outer thread diameter  $d \geq 8$  mm are driven into the wood-based member without pre-drilling, the structural solid or glued laminated timber, laminated veneer lumber and similar glued members shall be from spruce, pine or fir.

By fastening screws in wood-based members (eg. OSB; Particleboard; Fibreboard) the head of the screws shall be flush with the surface of the wood-based member.

<sup>12</sup> EN 1995-1-1:2004+A1:2008+A2:2014

Design of timber structures – Part 1-1: General – Common rules and  
rules for buildings

## Annex 2 Characteristic values of the load-bearing capacity

	EJOT Pondus JW2-ZT 6,5xL	EJOT Pondus JW2-ZT 8,2xL
Outer thread diameter [mm]	6.5	8.2
Characteristic yield moment $M_{y,k}$ [Nm]	8.92	26.2
Characteristic tensile capacity $F_{tens,k}$ [kN]	13.88	19.45
Characteristic yield strength $f_{y,k}$ [N/mm <sup>2</sup> ]	957	943
Characteristic torsional strength $f_{tor,k}$ [Nm]	11.2	30.1
Bending angle	A minimum plastic bending angle of 90° was reached without breaking the screws.	
Insertion moment*	OK	OK
*Ratio of the characteristic torsional strength to the mean insertion moment: $f_{tor,k} / R_{tor,mean} > 1,5$		

Table A.2.1 Characteristic load-bearing capacities of EJOT Pondus screws

### A.2.1 General

The minimum penetration length of the threaded part of the screw  $l_{ef}$  shall be

$$l_{ef} = \min \left\{ \begin{array}{l} \frac{4 \cdot d}{\sin \alpha} \\ 20 \cdot d \end{array} \right. \quad (2.1)$$

where

$\alpha$  angle between screw axis and grain direction

$d$  outer thread diameter of the screw.

The inner thread diameter  $d_1$  of the screws shall be greater than the maximal width of the gaps in the layer of cross laminated timber.

### A.2.2 Laterally loaded screws

The outer thread diameter  $d$  shall be used as effective diameter of the screw according to EN 1995-1-1.

The embedding strength for the screws in wood-based members or in wood-based panels shall be taken from EN 1995-1-1 or from national provisions that apply at the installation site.

### A.2.3 Axially loaded screws

#### A.2.3.1 Axial slip modulus

Screw dimension [mm]	$K_{ser}$ [kN/mm]
6.5 x 90	17.6
6.5 x 130	18.7*
6.5 x 160	28.0
6.5 x 190	35.6*
6.5 x 220	43.1
8.2 x 160	21.8
8.2 x 190	23.7*
8.2 x 220	28.0*
8.2 x 245	26.9
8.2 x 280	30.9*
8.2 x 300	39.5*
8.2 x 330	39.6

Table A.2.2 Axial Slip Modulus for strength grade C24 with characteristic raw density of 350 kg/m<sup>3</sup>

\*The value is an interpolation based on the mean slip modulus of each tested diameter.

The mean slip modulus has been calculated via the length of the thread embedded in the wood.

### A.2.3.2 Axial withdrawal capacity

The characteristic withdrawal capacity in solid timber, glued laminated timber or cross laminated timber members at an angle of at least 15° to the grain shall be calculated as:

$$F_{ax,\alpha,Rk} = \frac{n_{ef} \cdot k_{ax} \cdot f_{ax,k} \cdot d \cdot l_{ef}}{k_{\beta}} \cdot \left(\frac{\rho_k}{\rho_a}\right)^{0,8} \quad (2.2)$$

where

$F_{ax,\alpha,Rk}$  Characteristic withdrawal capacity of a screw group at an angle  $\alpha$  to the grain [N]

$n_{ef}$  Effective number of screws according to EN 1995-1-1, clause 8.7.2 (8)

$k_{ax}$  Factor, taking into account the angle  $\alpha$  between screw axis and grain direction

$$k_{ax} = 1.0 \quad \text{for } 45^\circ \leq \alpha \leq 90^\circ$$

$$k_{ax} = a + \frac{b \cdot \alpha}{45^\circ} \quad \text{for } 15^\circ \leq \alpha < 45^\circ \quad (2.3)$$

$$a = 0.3 \quad \text{for solid timber, glue solid timber, glue lam. timber, cross lam. timber}$$

$$b = 0.7 \quad \text{for solid timber, glue solid timber, glue lam. timber, cross lam. timber}$$

$$\text{if } l_{ef} = \min \begin{cases} \frac{4 \cdot d}{\sin \alpha} \\ 20 \cdot d \end{cases} \quad \text{and } \alpha \geq 15^\circ \quad k_{ax} \text{ may alternatively be taken as} \quad (2.4)$$

$$k_{ax} = \frac{1}{1.2 \cdot \cos^2 \alpha + \sin^2 \alpha} \quad (2.5)$$

$$k_{\beta} \quad k_{\beta} = 1.0 \quad \text{for solid timber, glue solid timber, glue lam. timber, CLT} \quad (2.6)$$

$f_{ax,k}$  Characteristic withdrawal parameter at an angle  $\alpha = 90^\circ$  based on a characteristic density of the wood-based member  $\rho_k$  of 350 kg/m<sup>3</sup>

$$f_{ax,k} = 13.3 \text{ N/mm}^2 \text{ for } d = 6.5 \text{ mm}$$

$$f_{ax,k} = 13.8 \text{ N/mm}^2 \text{ for } d = 8.2 \text{ mm}$$

The characteristic withdrawal parameter is also valid for softwood layers of cross-laminated timber.

$l_{ef}$  penetration length of the threaded part of the screw in the wood-based member [mm]

$\rho_k$  Characteristic density of the wood-based member, for LVL  $\rho_k \leq 500 \text{ kg/m}^3$ .



For screws penetrating more than one layer of cross laminated timber the different layers may be taken into account proportionally. In the lateral surfaces of the cross laminated timber the screws shall be fully inserted in one layer of cross-laminated timber.

### A.2.3.3 Head pull-through capacity

For screws with a head diameter of at least 1.8 times the shank or inner thread diameter the characteristic head pull-through parameter may be determined by calculation. For solid softwood according to EN 14081-1 and glued laminated timber made from softwood according to EN 14080 a characteristic density of  $\rho_k = 350 \text{ kg/m}^3$  shall be used in equation (8.40b) of EN 1995-1-1.

The characteristic value of the head pull-through parameter for a characteristic density of  $380 \text{ kg/m}^3$  for wood-based panel like

- Plywood according to EN 636 and EN 13986
- Oriented Strand Board, OSB according to EN 300 and EN 13986
- Particleboard according to EN 312 and EN 13986
- Fibreboards according to EN 622-2, EN 622-3 and EN 13986
- Cement-bonded particle boards according to EN 634-2 and EN 13986
- Solid-wood panels according to EN 13353 and EN 13986

with a thickness of more than 20 mm is

$$f_{\text{head,k}} = 10.0 \text{ N/mm}^2$$

For wood-based panels a maximum characteristic density of  $380 \text{ kg/m}^3$  and for LVL a maximum characteristic density of  $500 \text{ kg/m}^3$  shall be used in equation (8.40b) of EN 1995-1-1.

For wood-based panels with a thickness  $12 \text{ mm} \leq t \leq 20 \text{ mm}$  the characteristic value of the head pull-through parameter for EJOT Pondus screws is:

$$f_{\text{head,k}} = 8 \text{ N/mm}^2$$

For wood-based panels with a thickness of less than 12 mm the characteristic head pull-through capacity for EJOT Pondus screws shall be based on a characteristic value of the head pull-through parameter of  $8 \text{ N/mm}^2$ , and limited to 400 N complying with the minimum thickness of the wood-based panels of  $1.2 \cdot d$ , with  $d$  as outer thread diameter and the values in Table A.2.3.

Wood based panel	Minimum thickness [mm]
Plywood	6
Fibreboards (hardboards and mediumboards)	6
Oriented Strand Boards (OSB)	8
Particleboards	8
Cement-bonded particle board	8
Solid wood Panels	12

Table A.2.3 Minimum thickness of wood-based panels

For EJOT Pondus screws the withdrawal capacity of the thread in the wood-based member with the screw head may be taken into account instead of the head pull-through capacity, if the verification is carried out in accordance with Annex A.2.3.2.

### A.2.3.4 Compressive capacity

The design axial capacity  $F_{ax,Rd}$  of EJOT Pondus screws embedded in solid timber, glued solid timber or glued laminated timber made from softwood with an angle between screw axis and grain direction of  $30^\circ \leq \alpha \leq 90^\circ$  is the minimum of the axial resistance against pushing-in and the buckling resistance of the screw.

$$F_{ax,Rd} = \min \{ k_{ax} \cdot f_{ax,d} \cdot d \cdot l_{ef}; \kappa_c \cdot N_{pl,d} \} \quad (2.7)$$

$k_{ax}$  Factor, taking into account the angle  $\alpha$  between screw axis and grain direction according to Annex A.2.3.2

$f_{ax,d}$  design value of the axial withdrawal capacity of the threaded part of the screw [N/mm<sup>2</sup>]

$d$  outer thread diameter of the screw [mm]

$l_{ef}$  penetration length of the threaded part of the screw in the timber member [mm]

$$\kappa_c = 1 \quad \text{for } \bar{\lambda}_k \leq 0,2 \quad (2.8)$$

$$\kappa_c = \frac{1}{k + \sqrt{k^2 - \bar{\lambda}_k^2}} \quad \text{for } \bar{\lambda}_k > 0,2 \quad (2.9)$$

$$k = 0,5[1 + 0,49 + (\bar{\lambda}_k - 0,2) + \bar{\lambda}_k^2] \quad (2.10)$$

$$\text{and a relative slenderness ratio } \bar{\lambda}_k = \sqrt{\frac{N_{pl,k}}{N_{ki,k}}} \quad (2.11)$$

where

$N_{pl,k}$  char. plastic normal force related to the net cross-section of the inner thread diameter:

$$N_{pl,k} = \pi * \frac{d_1^2}{4} * f_{y,k} \quad (2.12)$$

$f_{y,k}$  characteristic yield strength

$f_{y,k} = 957 \text{ N/mm}^2$  for  $d = 6.5$

mm

$f_{y,k} = 943 \text{ N/mm}^2$  for  $d = 8.2$

mm

$d_1$  inner thread diameter of the screw

$$N_{pl,d} = \frac{N_{pl,k}}{\gamma_{M1}} \quad (2.13)$$

$\gamma_{M1}$  partial safety factor to EN 1993-1-1 in conjunction with the particular national annex

characteristic critical buckling load:

$$N_{ki,k} = \sqrt{c_h * E_S * I_S} \quad [\text{N}] \quad (2.14)$$

elastic foundation of the screw:

$$c_h = (0,19 * 0,012 * d) * \rho_k * \left(\frac{90^\circ + \alpha}{180^\circ}\right) \quad [\text{N/mm}^2] \quad (2.15)$$

$\rho_k$  characteristic density of the wood based member [ $\text{kg/m}^3$ ]

$\alpha$  angle between screw axis and grain direction,  $30^\circ \leq \alpha \leq 90^\circ$

modulus of elasticity:

$$E_s = 210.000 \text{N/mm}^2$$

Second moment of the area:

$$I_s = \frac{\pi * d_1^4}{64} [\text{mm}^4] \quad (2.16)$$

#### A.2.4 Spacing, end and edge distances of the screws and minimum thickness of the wood-based material

For EJOT Pondus screws in non-predrilled holes minimum spacing and distances are given in EN 1995-1-1, clause 8.3.1.2 and Table 8.2 as for nails in non-predrilled holes. Here, the outer thread diameter  $d$  shall be considered.

Minimum distances from loaded or unloaded ends must be  $15 \cdot d$  for screws in non-predrilled holes with outer thread diameter  $d > 8$  mm and timber thickness  $t < 5 \cdot d$ .

For Douglas fir members minimum spacing and distances parallel to the grain shall be increased by 50%.

Unless otherwise specified, minimum thickness for non-predrilled structural members is:

$t = 30$  mm for screws with outer thread diameter  $d = 6.5$  mm

$t = 40$  mm for screws with outer thread diameter  $d = 8.2$  mm.

##### Cross-Laminated-Timber CLT

Minimum distances and spacing (*Figure A.2.1*) for screws in the plane surface of cross laminated timber members with a minimum thickness  $t_{CLT} = 10 \cdot d$  may be taken as:

Spacing $a_1$ parallel to the grain	$a_1 = 4 \cdot d$
Spacing $a_2$ perpendicular to the grain	$a_2 = 2,5 \cdot d$
Distance $a_{3,c}$ from centre of the screw-part in timber to the unloaded end grain	$a_{3,c} = 6 \cdot d$
Distance $a_{3,t}$ from centre of the screw-part in timber to the loaded end grain	$a_{3,t} = 6 \cdot d$
Distance $a_{4,c}$ from centre of the screw-part in timber to the unloaded edge	$a_{4,c} = 2,5 \cdot d$
Distance $a_{4,t}$ from centre of the screw-part in timber to the loaded edge	$a_{4,t} = 6 \cdot d$

Minimum distances and spacing (*Figure A.2.2*) for screws in the edge surface of cross laminated timber members with a minimum thickness  $t_{CLT} = 10 \cdot d$  and a minimum penetration depth perpendicular to the edge surface may be taken as:

Spacing $a_1$ parallel to the CLT plane	$a_1 = 10 \cdot d$	
Spacing $a_2$ perpendicular to the CLT plane	$= 4 \cdot d$	$a_2$
Distance $a_{3,c}$ from centre of the screw-part in timber to the unloaded end	$a_{3,c} = 7 \cdot d$	
Distance $a_{3,t}$ from centre of the screw-part in timber to the loaded end	$a_{3,t} = 12 \cdot d$	
Distance $a_{4,c}$ from centre of the screw-part in timber to the unloaded edge	$a_{4,c} = 3 \cdot d$	
Distance $a_{4,t}$ from centre of the screw-part in timber to the loaded edge	$a_{4,t} = 6 \cdot d$	

**A.2.5 Axially or laterally loaded screws in the plane or edge surface of cross laminated timber**

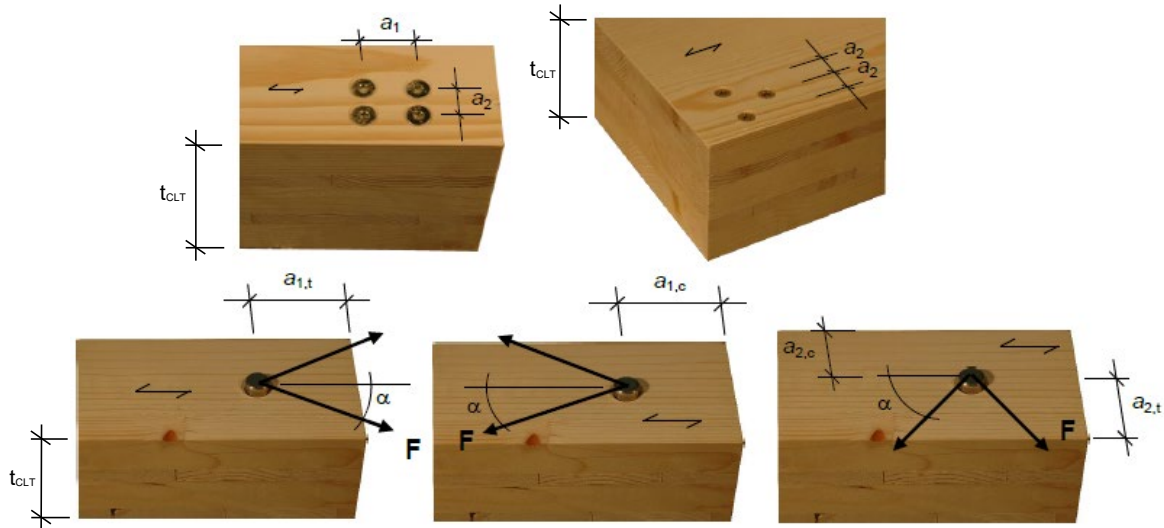

Figure A.2.1 Definition of spacing, end and edge distances in the plane surface unless otherwise specified in the technical specification for cross laminated timber

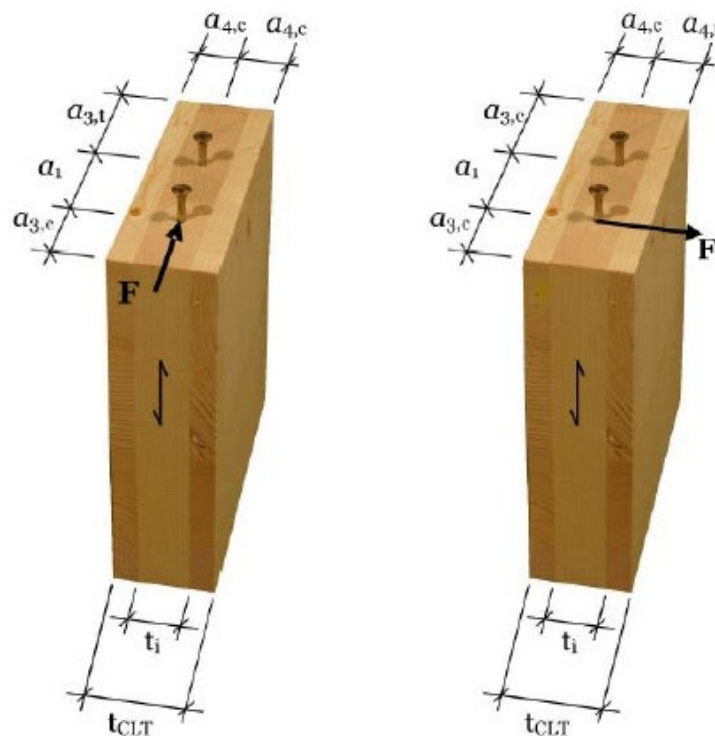

Figure A.2.2 Definition of spacing, end and edge distances in the edge surface unless otherwise specified in the technical specification for cross laminated timber

### **A.2.6 Insertion moment**

The ratio between the characteristic torsional strength  $f_{\text{tor},k}$  and the mean value of insertion moment  $R_{\text{tor,mean}}$  fulfills the requirement for all screws.

### **A.2.7 Durability against corrosion**

The screws are coated with the zinc flake system or they are electrogalvanized with zinc (minimum thickness: 5  $\mu\text{m}$ ).

## Annex 3 Compression reinforcement perpendicular to the grain

### A.3.1 General

EJOT Pondus screws may be used for compression reinforcement perpendicular to the grain. The provisions are valid for reinforcing timber members made from solid timber, glued solid timber or glue laminated timber made from softwood.

The compression force shall evenly be distributed to the screws used as compression reinforcement.

The screws are driven into the timber member perpendicular to the contact surface under an angle between the screw axis and the grain direction of 45° to 90°. The screw head must be flush with the timber surface.

### A.3.2 Design

For the design of reinforced contact areas, the following conditions must be met independently of the angle between the screw axis and the grain direction.

The design resistance of a reinforced contact area is:

$$R_{90,d} = \min. \left\{ \frac{k_{c,90} * B * l_{ef,1} * f_{c,90,d} + n * \min\{R_{ax,d}; \kappa_c * N_{pl,d}\}}{B * l_{ef,2} * f_{c,90,d}} \right\} \quad (3.1)$$

where

$k_{c,90}$	Parameter acc. to EN 1995-1-1, clause 6.1.5
$B$	Bearing width [mm]
$l_{ef,1}$	Effective contact length acc. to EN 1995-1-1, clause 6.1.5 [mm]
$f_{c,90,d}$	Design compressive strength perpendicular to the grain [N/mm <sup>2</sup> ]
$n$	number of reinforcing screws, $n = n_0 * n_{90}$
$n_0$	Number of reinforcing screws arranged in a row parallel to the grain
$n_{90}$	Number of reinforcing screws arranged in a row perpendicular to the grain
$R_{ax,d}$	$= f_{ax,d} * d * l_{ef}$ [N]
$f_{ax,d}$	design value of the axial withdrawal capacity of the threaded part of the screw [N/mm <sup>2</sup> ]
$d$	outer thread diameter
$\kappa_c$	according to Annex A 2.3.4.
$N_{pl,d}$	according to Annex A 2.3.4.
$l_{ef,2}$	effective contact length in the plane of the screw tip (see figure 3.1) [mm] $l_{ef,2} = \{l_{ef} + (n_0 - 1) * a_1 + \min(l_{ef}; a_{1,c})\}$ for end supports (see figure 3.1 left) $l_{ef,2} = \{2 * l_{ef} + (n_0 - 1) * a_1\}$ for intermediate supports (see figure 3.1 right)
$l_{ef}$	Penetration length of the threaded part of the screw in the timber member [mm]
$a_1$	Spacing $a_1$ in a plane parallel to grain, see chapter A.2.4 [mm]
$a_{1,CG}$	End distance of the centre of gravity of the threaded part in the timber member, see chapter A.2.4



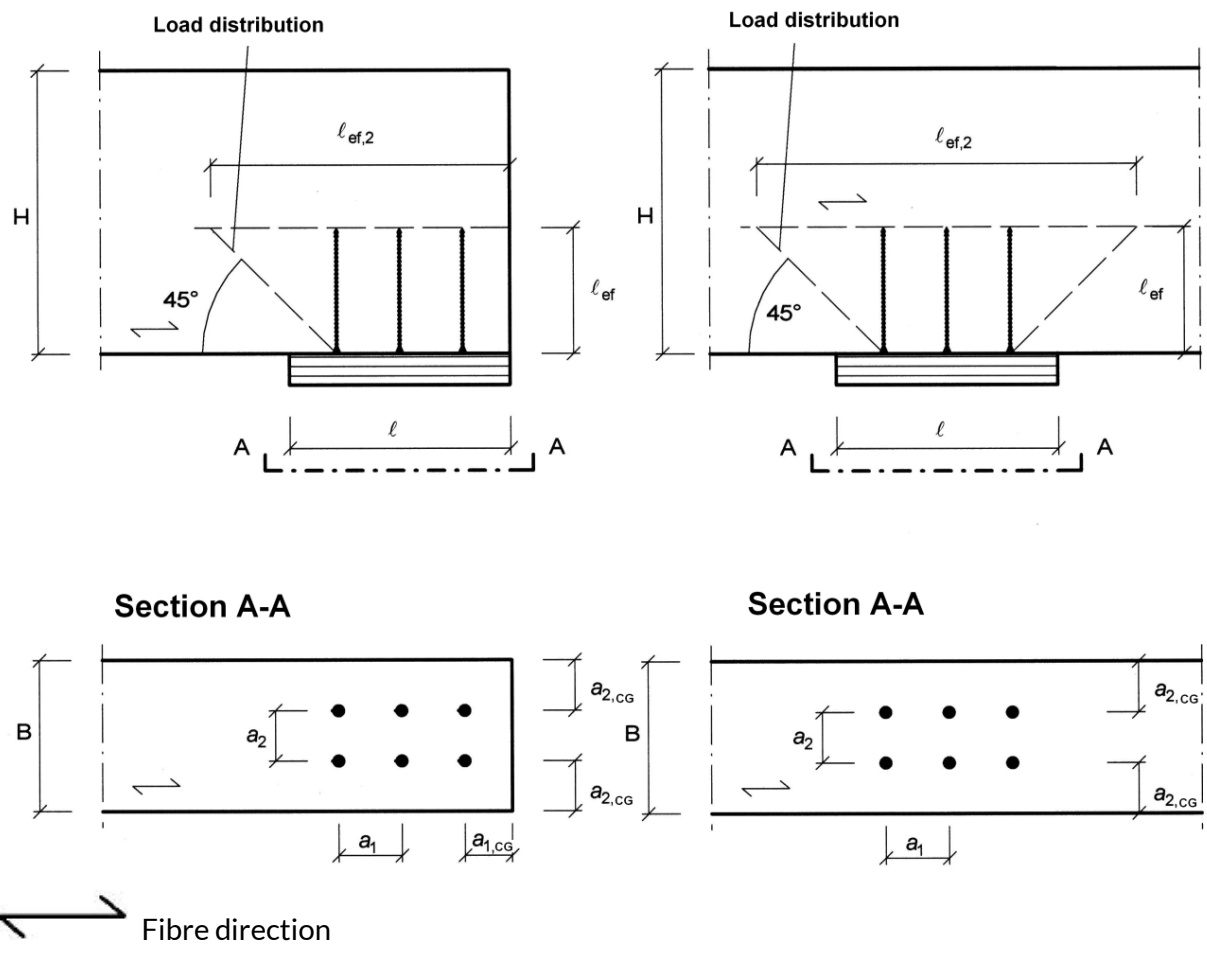

Figure A.3.1. Reinforced end support (left) and reinforced intermediate support (right)

## Annex 4 Fastening of thermal insulation on top of rafters

### A.4.1 General

The characteristic load-bearing capacity for header-joint connections with inclined screws ( $\alpha = 45^\circ$ ) should be calculated as:

EJOT Pondus screws with an outer thread diameter of at least 6mm may be used for the fixing of thermal insulation material on top of rafters or on wood-based members in vertical facades. In the following the meaning of the word rafter includes wood-based members with inclinations between  $0^\circ$  and  $90^\circ$ .

The thickness of the thermal insulation material may be up to 400mm. The thermal insulation material shall be applicable as insulation on top of rafters or for facades acc. to national provisions that apply at the installation site.

The battens have to be from solid timber acc. to EN 338<sup>13</sup>/EN 14081-1<sup>14</sup>. The minimum thickness  $t$  and the minimum width  $b$  of the battens are given in Table A.4.1

Outer thread diameter [mm]	Minimum thickness $t$ [mm]	Minimum width $b$ [mm]
6.5	30	50
8.2	40	50

Table A.4.1 Minimum thickness and minimum width of the battens

The minimum width of the rafters shall be 60 mm.

The spacing between screws shall not be more than 1.75 m.

Friction forces shall not be considered for the design of the characteristic axial loading of the screws.

The anchorage of wind suction forces as well as the bending stresses of the battens shall be considered for design.

Screws perpendicular to the grain of the rafter (angle  $\alpha = 90^\circ$ ) may be arranged where required considering the design of the battens.

<sup>13</sup> EN 338:2016

Structural Timber – Strength classes

<sup>14</sup> EN 14081-1:2016

Timber structures – Strength graded structural timber with rectangular cross section – General requirements

## **A.4.2 Parallel inclined screws and thermal insulation material in compression**

### **A.4.2.1 Mechanical model**

The system of rafter, thermal insulation material on top of rafter and counter battens parallel to the rafter may be considered as a beam on elastic foundation. The counter battens represent the beam, and the thermal insulation material on top of the rafter the elastic foundation. The minimum compressive stress of the thermal insulation material at 10% deformation, measured acc. to EN 826<sup>15</sup>, shall be  $\sigma_{(10\%)} = 0.05 \text{ N/mm}^2$ . The counter batten is loaded perpendicular to the axis by point loads  $F_b$  transferred by regular spaced battens. Further point loads  $F_s$  are caused by the shear load of the roof due to dead and snow load, which are transferred from the screw heads into the counter battens.

Instead of battens the following wood-based panels may be used to cover the thermal insulation material if they are suitable for that use:

- Plywood acc. to EN 636 and EN 13986
- Oriented Strand Board, OSB acc. to EN 300 and EN 13986
- Particleboard acc. to EN 312 and EN 13986
- Fibreboards acc. to EN 622-2, EN 622-3 and EN 13986

The minimum thickness of the wood-based panels shall be 22 mm.

The word batten includes the meaning of the above mentioned wood-based panels in the following.

<sup>15</sup> EN 826:2013

Thermal insulating products for building applications – Determination of compression behavior

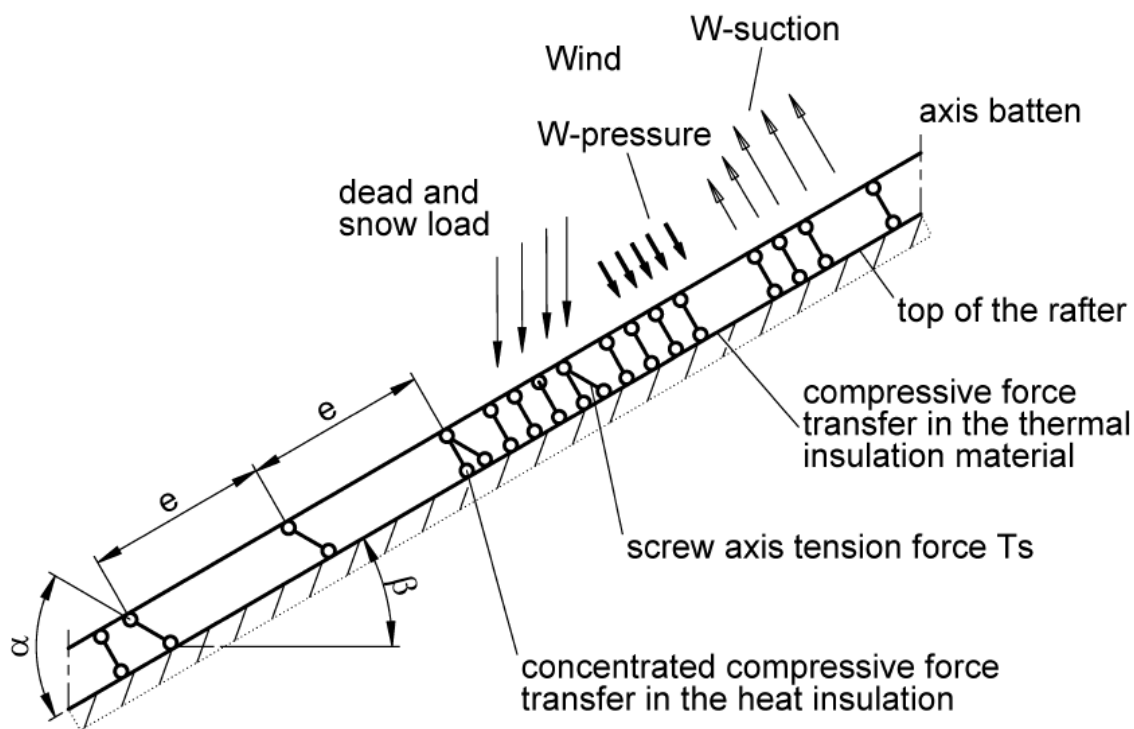
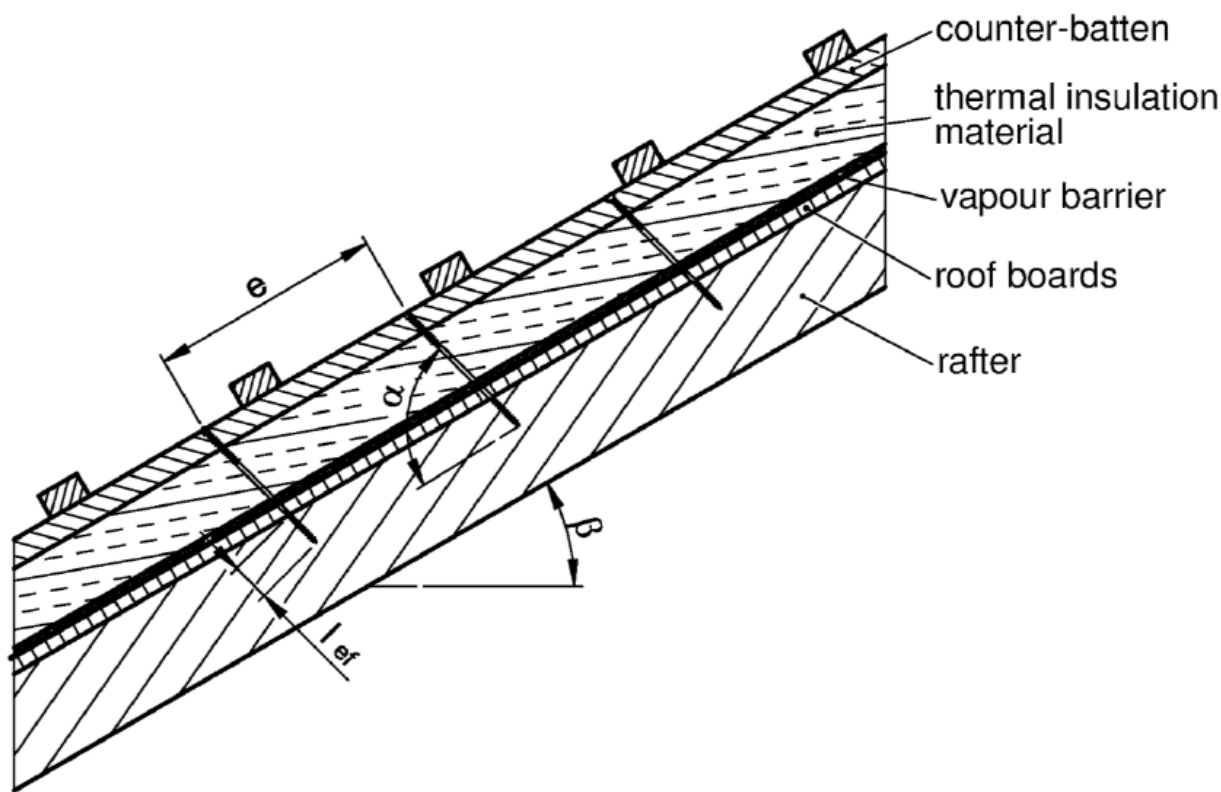

Figure A.4.1. Fastening of the thermal insulation material on top of rafters – structural system

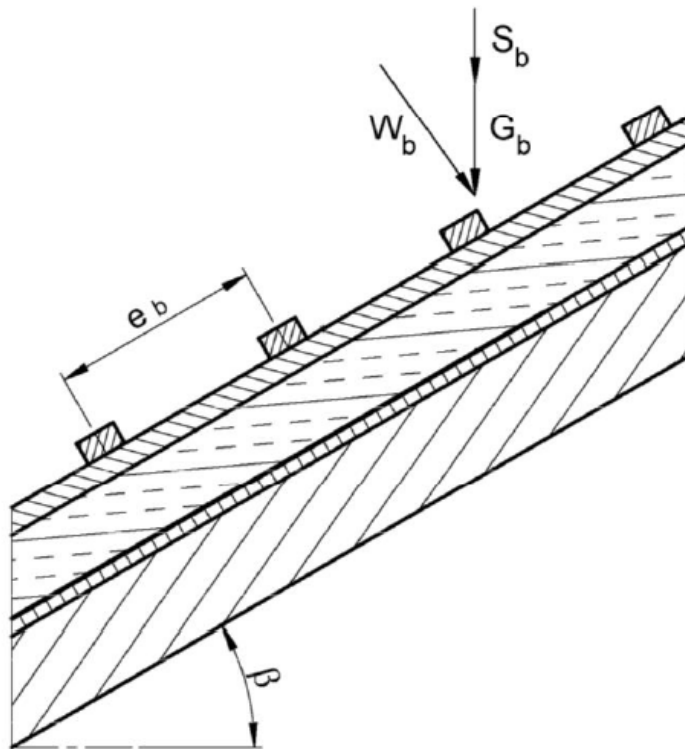

Figure A.4.2. Point loads  $F_b$  perpendicular to the battens

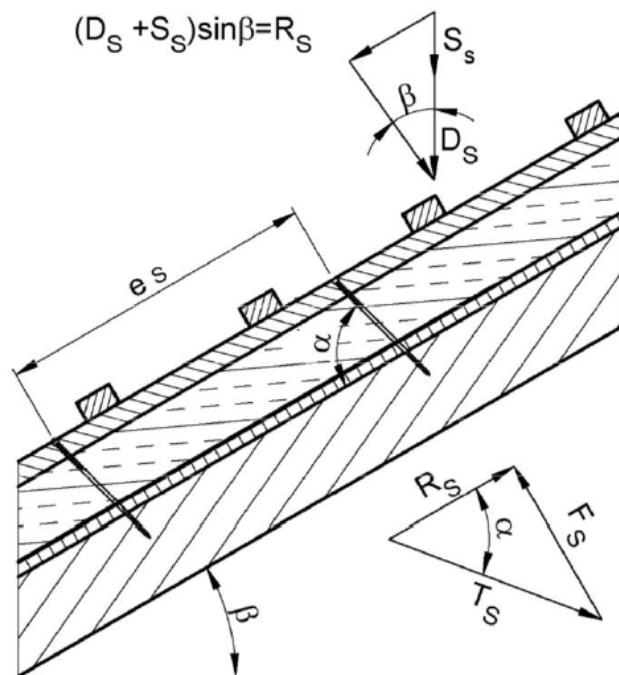

Figure A.4.3. Point loads  $F_s$  perpendicular to the battens, load application in the area of the screw heads

### A.4.2.2 Design of the battens

It is assumed that the spacing between the counter battens exceeds the characteristic length  $l_{char}$ . The characteristic values of the bending stresses are calculated as:

$$M_k = \frac{(F_{b,k} + F_{s,k}) * l_{char}}{4} \quad (4.1)$$

where

$$l_{char} \quad \text{characteristic length } l_{char} = \sqrt[4]{\frac{4 * EI}{w_{ef} * K}} \quad (4.2)$$

EI	bending stiffness of the batten
K	coefficient of subgrade
$w_{ef}$	effective width of the thermal insulation material
$F_{b,k}$	point loads perpendicular to the battens
$F_{s,k}$	point loads perpendicular to the battens, load application in the area of the screw heads

The coefficient of subgrade K may be calculated from the modulus of elasticity  $E_{HI}$  and the thickness  $t_{HI}$  of the thermal insulation material if the effective width  $w_{ef}$  of the thermal insulation material under compression is known.

Due to the load extension in the thermal insulation material the effective width  $w_{ef}$  is greater than the width of the batten or rafter, respectively. For further calculations, the effective width  $w_{ef}$  of the thermal insulation material may be determined according to:

$$w_{ef} = w + t_{HI}/2 \quad (4.3)$$

where

w minimum from width of the batten or rafter, respectively

$t_{HI}$  thickness of the thermal insulation material

$$K = \frac{E_{HI}}{t_{HI}} \quad (4.4)$$

The following condition shall be satisfied:

$$\frac{\sigma_{m,d}}{f_{m,d}} = \frac{M_d}{W * f_{m,d}} \leq 1 \quad (4.5)$$

For the calculation of the section modulus W the net cross section shall be considered.

The characteristic values of the shear stresses shall be calculated acc.to:

$$V_k = \frac{(F_{b,k} + F_{s,k})}{2} \quad (4.6)$$

The following condition need to be satisfied:

$$\frac{\tau_d}{f_{v,d}} = \frac{1.5 \cdot V_d}{A \cdot f_{v,d}} \leq 1 \quad (4.7)$$

For the calculation of the cross-section area the net cross section shall be considered.

#### A.4.2.3 Design of the thermal insulation material

The characteristic value of the compressive stresses in the thermal insulation material shall be calculated acc. to:

$$\sigma_k = \frac{1.5 \cdot F_{b,k} + F_{s,k}}{2 \cdot l_{char} \cdot w} \quad (4.8)$$

The design value of the compressive stress shall not be greater than 110% of the compressive strength at 10% deformation calculated acc. to EN 826<sup>16</sup>.

#### A.4.2.4 Design of the screws

The screws are loaded predominantly axial. The characteristic value of the axial tension force in the screw may be calculated from the shear loads of the roof  $R_s$ .

$$T_{S,k} = \frac{R_{S,k}}{\cos \alpha} \quad (4.9)$$

The load-carrying capacity of axially loaded screws is the minimum design value of the axial withdrawal capacity of the threaded part of the screw, the head pull-through capacity of the screw and the tensile capacity of the screw acc. to Annex 2.

In order to limit the deformation of the screw head for the thermal insulation material with the thickness over 220mm or with compressive strength below 0.12 N/mm<sup>2</sup>, respectively, the axial withdrawal capacity of the screws shall be reduced by the factors  $k_1$  and  $k_2$ :

$$F_{ax,\alpha,Rd} = \min \left\{ \frac{k_{ax} \cdot f_{ax,d} \cdot d \cdot l_{ef} \cdot k_1 \cdot k_2}{k_{\beta}} \cdot \left( \frac{\rho_k}{350} \right)^{0.8}; f_{head,d} \cdot d_h^2 \cdot \left( \frac{\rho_k}{350} \right)^{0.8}; \frac{F_{tens,k}}{\gamma_{M2}} \right\} \quad (4.10)$$

<sup>16</sup> EN 826:2013

Thermal insulating products for building applications – Determination of compression behavior

$k_{ax}$	Factor acc. to Annex A.2.3.2, taking into account the angle $\alpha$ between screw axis and grain direction
$f_{ax,d}$	design value of the axial withdrawal parameter of the threaded part of the screw in the rafter [N/mm <sup>2</sup> ]
$d$	outer thread diameter [mm]
$l_{ef}$	penetration length of the threaded part of the screw in the rafter [mm], $l_{ef} \geq 40\text{mm}$
$\rho_k$	characteristic density of the wood based member [kg/m <sup>3</sup> ], for beech, ash and oak $\rho_k \leq 590 \text{ kg/m}^3$ and for LVL (softwood) $\rho_k \leq 500 \text{ kg/m}^3$
$\alpha$	angle $\alpha$ between screw axis and grain direction, $30^\circ \leq \alpha \leq 90^\circ$
$f_{head,k}$	design value of the head pull-through parameter of the screw [N/mm <sup>2</sup> ]
$d_h$	head diameter of the screw
$F_{tens,k}$	characteristic tensile capacity of the screw according to Annex 2, Table A.2.1 [N]
$\gamma_{M2}$	partial factor acc. to EN 1993-1-1 in conjunction with the particular national annex
$k_1$	$\min \{1; 220/t_{HI}\}$
$k_2$	$\min \{1; \sigma_{10\%}/0.12\}$
$t_{HI}$	thickness of the thermal insulation material [mm]
$\sigma_{10\%}$	compressive stress of the thermal insulation material under 10% deformation [N/mm <sup>2</sup> ]
$k_\beta$	Factor acc. to Annex A.2.3.2

If equation (5.10) is fulfilled, the deflection of the battens does not need to be considered when designing the load-carrying capacity of the screws.

### **A.4.3 Alternatively inclined screws and thermal insulation material non in compression**

#### **A.4.3.1 Mechanical model**

Depending on the screw spacing and the arrangement of tensile and compressive screws with different inclinations the battens are loaded by significant bending moments. The bending moments are derived based on the following assumptions:

The tensile and compressive loads in the screws are determined based on equilibrium conditions from the actions parallel and perpendicular to the roof plane. These actions are constant line loads  $q_\perp$  and  $q_\parallel$ .

The screws act as hinged columns supported 100mm within the batten or rafter, respectively. The effective column length consequently equals the length of the screw between batten and rafter plus 20mm.



The batten is considered as a continuous beam with a constant span  $l = A + B$ . The compressive screws constitute the support of the continuous beam while the tensile screws transfer concentrated loads perpendicular to the batten axis.

The screws are predominantly loaded in withdrawal or compression, respectively. The characteristic values of the screw's normal forces are determined on the loads parallel and perpendicular to the roof plane:

$$\text{Compressive screw: } N_{c,k} = (A + B) * \left( -\frac{q_{\parallel,k}}{\cos\alpha_1 + \sin\alpha_1/\tan\alpha_2} - \frac{q_{\perp,k} * \sin(90-\alpha_2)}{\sin(\alpha_1+\alpha_2)} \right) \quad (4.11)$$

$$\text{Tensile screw: } N_{t,k} = (A + B) * \left( -\frac{q_{\parallel,k}}{\cos\alpha_2 + \sin\alpha_2/\tan\alpha_1} - \frac{q_{\perp,k} * \sin(90-\alpha_1)}{\sin(\alpha_1+\alpha_2)} \right) \quad (4.12)$$

- A distance of the screws acc. to Figure A.7.5
- B distance of the alternatively inclined screws acc. to Figure A.5.5
- $q_{\parallel,k}$  characteristic value of the loads parallel to the roof plane
- $q_{\perp,k}$  characteristic value of the loads perpendicular to the roof plane
- $\alpha$  angle  $\alpha_1$  and  $\alpha_2$  between screw axis and grain direction,  $30^\circ \leq \alpha_1 \leq 90^\circ$ ;  $30^\circ \leq \alpha_2 \leq 90^\circ$

Only screws with a full thread or a thread below the head and in the area of the drill tip shall be used.

The bending moments in the batten follow from the constant line load  $q_{\perp}$  and the load components perpendicular to the batten from the tensile screws. The span of the continuous beam is  $(A+B)$ . The characteristic value of the load component perpendicular to the batten from the tensile screw is:

$$F_{ZS,k} = (A + B) * \left( -\frac{q_{\parallel,k}}{1/\tan\alpha_1 + 1/\tan\alpha_2} - \frac{q_{\perp,k} * \sin(90-\alpha_1) * \sin\alpha_2}{\sin(\alpha_1+\alpha_2)} \right) \quad (4.13)$$

A positive value for  $F_{ZS,k}$  means a load towards the rafter, a negative value a load away from the rafter. The system of the continuous beam is shown in Figure A.4.5.

The battens or wood-based panels fixed on the rafter shall be supported perpendicular to the load-bearing plane.

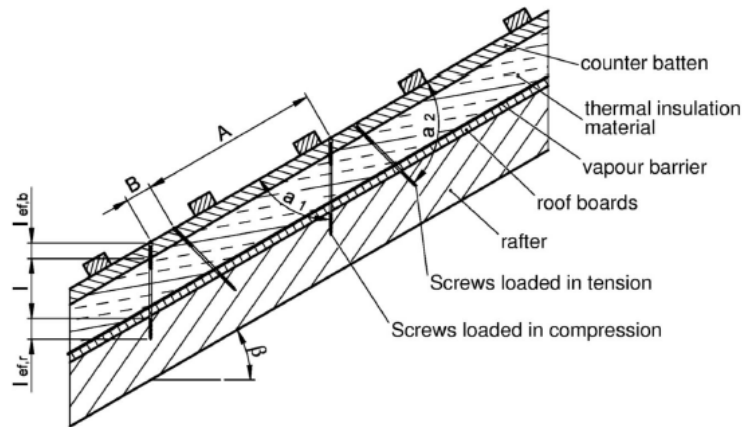

Figure A.4.4 Fastening of thermal insulation material on top of rafters – structural system for alternatively inclined screws

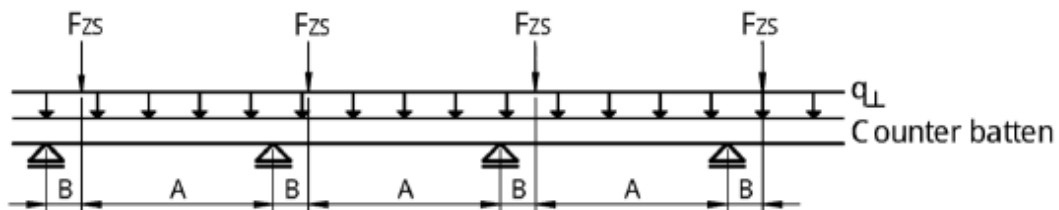

Figure A.4.5 Continuous battens under constant line loads from actions on the roof plane  $q$  and concentrated loads from tensile screws  $F_{ZS}$

### A.4.3.2 Design of the screws

The design value of the load-carrying capacity of the screws shall be calculated acc. to equations (4.14) and (4.15).

Screws loaded in tension:

$$F_{ax,\alpha,Rd} = \min \left\{ \frac{k_{ax} * f_{ax,d} * d * l_{ef,b}}{k_{\beta}} * \left( \frac{\rho_{b,k}}{350} \right)^{0.8} ; \frac{k_{ax} * f_{ax,d} * d * l_{ef,r}}{k_{\beta}} * \left( \frac{\rho_{r,k}}{350} \right)^{0.8} ; \frac{F_{tens,k}}{\gamma_{M2}} \right\} \quad (4.14)$$

Screws loaded in compression:

$$F_{ax,\alpha,Rd} = \min \left\{ \frac{k_{ax} * f_{ax,d} * d * l_{ef,b}}{k_{\beta}} * \left( \frac{\rho_{b,k}}{350} \right)^{0.8} ; \frac{k_{ax} * f_{ax,d} * d * l_{ef,r}}{k_{\beta}} * \left( \frac{\rho_{r,k}}{350} \right)^{0.8} ; \frac{\kappa_c * N_{pl,k}}{\gamma_{M1}} \right\} \quad (4.15)$$

- $k_{ax}$  Factor acc. to Annex A.2.3.2, taking into account the angle  $\alpha$  between screw axis and grain direction
- $f_{ax,d}$  design value of the axial withdrawal parameter of the threaded part of the screw in the rafter [N/mm<sup>2</sup>]
- $d$  outer thread diameter [mm]

$l_{ef,b}$	penetration length of the threaded part of the screw in the batten [mm]
$l_{ef,r}$	penetration length of the threaded part of the screw in the rafter, $l_{ef} \geq 40\text{mm}$ [mm]
$k_{\beta}$	Factor acc. to Annex A.2.3.2
$\rho_{b,k}$	characteristic density of the batten [ $\text{kg}/\text{m}^3$ ], for beech, ash and oak $\rho_k \leq 590 \text{ kg}/\text{m}^3$ and for LVL (softwood) $\rho_k \leq 500 \text{ kg}/\text{m}^3$
$\rho_{r,k}$	characteristic density of the rafter [ $\text{kg}/\text{m}^3$ ], for beech, ash and oak $\rho_k \leq 590 \text{ kg}/\text{m}^3$ and for LVL (softwood) $\rho_k \leq 500 \text{ kg}/\text{m}^3$
$\alpha$	angle $\alpha$ between screw axis and grain direction, $30^\circ \leq \alpha \leq 90^\circ$
$F_{tens,k}$ [ $\text{N}/\text{mm}^2$ ]	characteristic tensile capacity of the screw according to Annex 2, Table A.2.1
$\gamma_{M1}, \gamma_{M2}$	partial factor acc. to EN 1993-1-1 in conjunction with the particular national annex
$\kappa_c * N_{pl,k}$	Buckling capacity of the screw acc. screw to table A.4.2 [kN]

Free screw length $l$ between batten and rafter [mm]	EJOT Pondus JW2-ZT 6.5xL	EJOT Pondus JW2-ZT 8.2xL
	$\kappa_c * N_{pl,k}$ [kN]	
$\leq 100$	4.37	12.34
120	3.34	9.64
140	2.63	7.70
160	-	6.27
180	-	5.20
200	-	4.38
220	-	3.73
240	-	3.22

Table A.4.2. Characteristic load-carrying capacity of EJOT Pondus screws  $\kappa_c * N_{pl,k}$ , dimensions in [kN]

## Annex 5 Dimensions

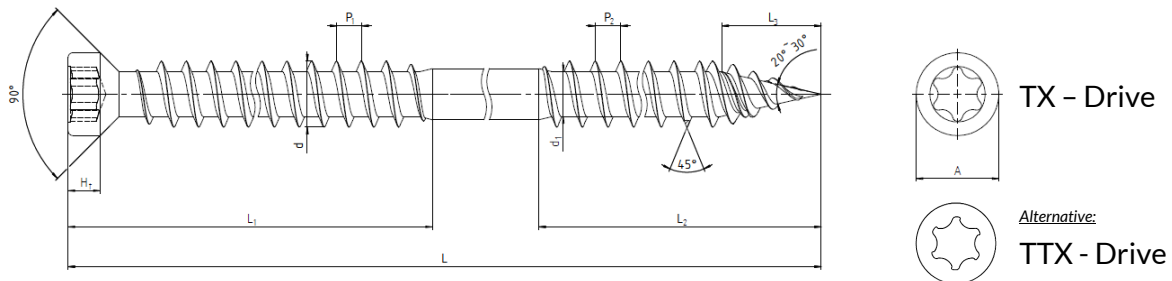

### Designation:

EJOT Pondus JW2-ZT-6.5xL-L1/L2-V-T30 // EJOT Pondus JW2-ZT-8.2xL-L1/L2-V-T40  
 EJOT Pondus JW2-ZT-6.5xL-L1/L2-R-T30 // EJOT Pondus JW2-ZT-8.2xL-L1/L2-R-T40

### Surface treatment:

V – electrogalvanized zinc plating  
 R – zinc flake coating

Type	Size	Drive	A	d	d <sub>1</sub>	P <sub>1</sub>	P <sub>2</sub>	H <sub>t</sub>	L	L <sub>1</sub>	L <sub>2</sub>	L <sub>3</sub>
EJOT Pondus JW2- ZT- 6.5xL	6.5x L	TX30/ / TTX 30	8.0	6.5	3.85	2.8	3.0	6.4	90	40	40	9.5
									130	43	43	
									160	67	67	
									190	82	82	
									220	97	97	
EJOT Pondus JW2- ZT- 8.2xL	8.2x L	TX40/ / TTX4 0	10.3	8.2	5.62	3.1	3.2	8.6	160	67	67	17.0
									190	82	82	
									220	97	97	
									245	105	105	
									280	107	107	
									300	137	137	
									330	137	137	

Table A.5.1. Geometric Parameters of EJOT Pondus screws, dimensions in [mm]