

Typ 14/50-780C (Art.-Nr. 12000522)
Type

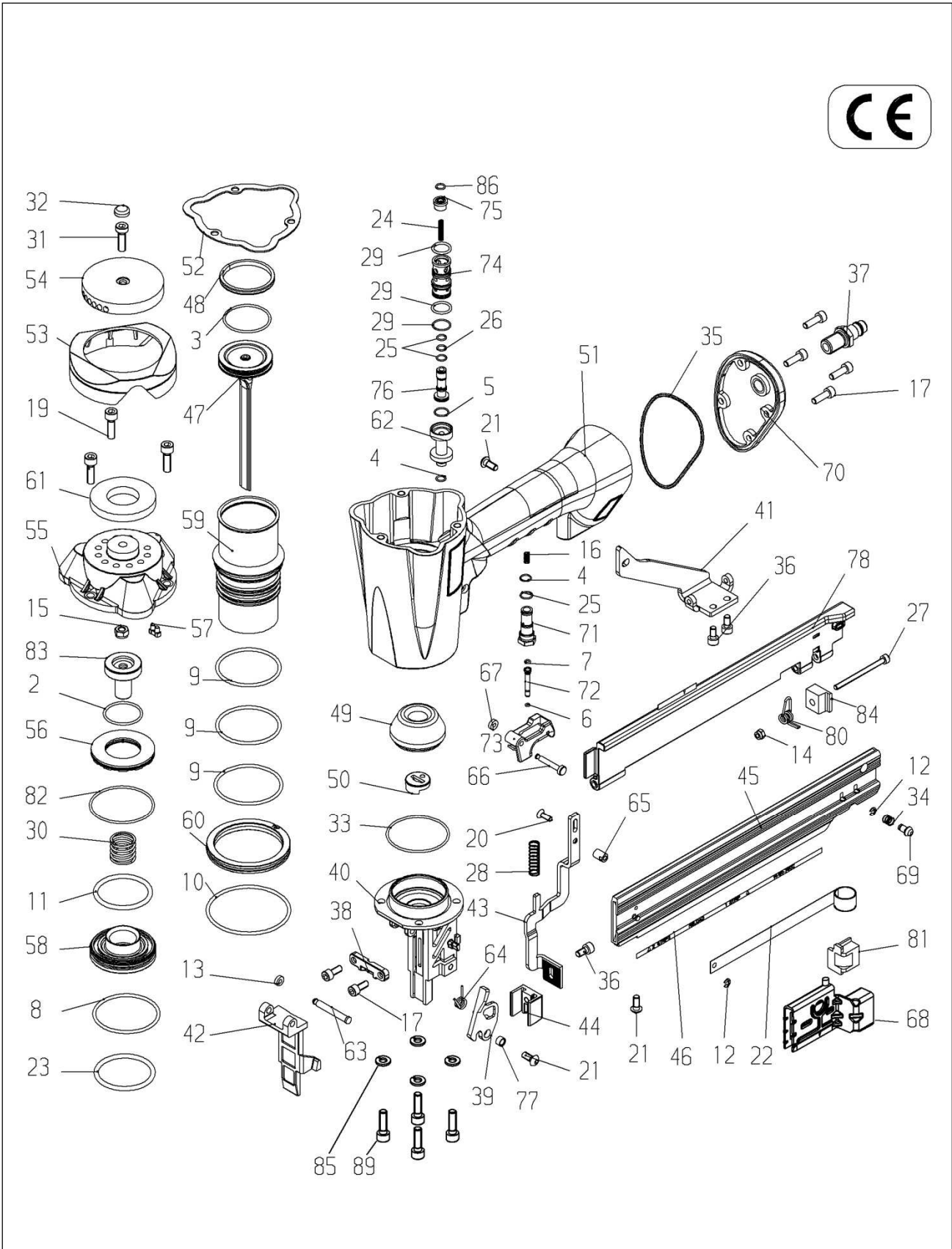

2	O-Ring	13300021	33	O-Ring	13303062	52	Kappendichtung	14408576	71	Ventilbuchse	14407761
3	O-ring	13300026		O-ring			Cap seal			Valve bush	
4	Joint torique	13300051		Joint torique			Capuchon douille			Douille de soupape	
5	Aro torico	13304007		Aro torico			Cabeza de fijacion			Casquillo valvula	
6		13300060									
7		13300065	34	Druckfeder	13303063	53	Kappenabdeckung	14408784	72	Schaltstift	14407762
8		13300071		Compression spring			Cover			Valve pin	
9		13300091		Ressort à pression			Cache			Bouton de commande	
10		13300101		Muelle de presión			Tapa			Pasador valvula	
11		13300135									
12	Sicherungsscheibe	13300347	35	O-Ring	13303128	54	Luftleitdeckel	14408786	73	Ventilhebel, kompl.	14407946
	Retaining washer			O-ring			Air deflector			Trigger, compl	
	Clips			Joint torique			Couvercle de déflecteur			Levier de détente	
	Clip			Aro torico			Tapa deflector de aire			Palanca valvula gatillo	
13	Sicherungsring	13300355	36	Zylinderschraube	13303067	55	Kappe	14408579	74	Steuerhülse	14413986
	Circlip			Allan screw			Cap			Socket	
	Clips			Vis cylindrique			Capuchon			Douille	
	Aro de seguridad			Tornillo allen			Cabeza			Casquillo	
14	Sicherungsmutter	13300437	37	Stecknippel	14000244	56	Kappenscheibe	14408580	75	Steuerbuchse	14413759
15	Safety nut	13300439		Plug-in nipple			Cap disc			Valve bushing	
	Ecrou de sûreté			Raccord enfichable			Rondelle du capuchon			Douille de soupape	
	Tornillo de seguridad			Manguito enchufable			Arandela de cabeza			Casquillo valvula	
16	Druckfeder	13303110	38	Werkzeug Teil 1	14405972	57	Stopfen	14408617	76	Steuerkolben	14413758
	Compression spring			Front nose			Post cap			Piston	
	Ressort à pression			Plaque frontale			Capuchon			Piston	
	Muelle de presión			Placa guia delantera			Capuchon			Pistón	
17	Zylinderschraube	13301117	39	Hebel	14404564	58	Hauptventil	14408581	77	Buchse	14404565
19	Allan screw	13301137		Lever			Main valve			Bushing	
	Vis cylindrique			Levier			Soupape principale			Douille	
	Tornillo allen			Palanca			Valvula principal			Casquillo	
20	Senkschraube	13301273	40	Kopfstück	14409448	59	Zylinder	14408582	78	Abdeckschiene, kompl.	14409055
	Countersunk screw			Nose housing			Cylinder			Cover, cpl	
	Vis creuse fraisée			Tête			Cylindre			Rail de couverture, cpl	
	Tornillo avellanado			Testero			Cilindro			Tapa cargador, cpl	
21	Linsenschraube	13301352	41	Lasche	14408567	60	Zylinderring	14408583	80	Schenkelfeder	14404611
	Lens head screw			Hook plate			Cylinder spacer			Leg spring	
	Vis creuse fraisée			Plaque d'ancrage			Anneau de cylindre			Ressort à branches	
	Tornillo cabeza de la lente			Placa con ganchos			Espaciador del cilindro			Muelle en pata	
22	Rollfeder	13301614	42	Kopfstückklappe	14408783	61	Schalldämpfer	14408584	81	Rollfederführung	14404616
	Roller spring			Nose housing door			Silencer			Support for roller spring	
	Ressort enroulé			Clapet de la tête			Amortisseur de bruit			Plaque pour ressort enroulé	
	Muelle espiral			Puerta testero			Silenciador			Soporte para muelle en rollo	
23	O-Ring	13301758	43	Auslösebügel	14408785	62	Zwischenhülse	14414630	82	O-Ring	13300028
	O-ring			Safety yoke			Cylinder, intermediate valve			O-ring	
	Joint torique			Palpeur de sécurité			Arbre intermédiaire			Joint torique	
	Aro torico			Estribo de seguridad			Valvula intermedio cilindro			Aro torico	
24	Druckfeder	13301775	44	Auslöseschuh	14408870	63	Achse	14407740	83	Anschlagdämpfer	14409189
	Compression spring			Safety shoe			Pin			Piston stop	
	Ressort à pression			Sabot de déclencheur			Axe			Douille supérieure	
	Muelle de presión			Pedel de seguridad			Eje			Suplemento de tapa	
25	O-Ring	13302647	45	Klammerträger	14409577	64	Schenkelfeder	14408555	84	Vorschieberanschlag	14409485
26	O-ring	13300007		Staple carrier			Leg spring			Pusher stop	
	Joint torique			Support d'agrafes			Ressort à branches			Chariot butoir	
	Aro torico			Cargador grapas			Muelle en pata			Empujador tope	
27	Zylinderschraube	13302942	46	Aufkleber Magazin	14408616	65	Hülse	14407743	85	Federring	13300375
	Allan screw			Magazine label			Sleeve			Spring washer	
	Vis cylindrique	13303067		Étiquette			Douille			Clips	
	Tornillo allen			Etiqueta			Adaptador			Anillo elastico	
28	Druckfeder	13302990	47	Kolben, kompl	14408571	66	Ventilhebelstift	14407744	86	O-Ring	13300057
	Compression spring			Piston, cpl			Trigger valve stem			O-ring	
	Ressort à pression			Piston, cpl			Axe de levier de détente			Joint torique	
	Muelle de presión			Piston, cpl			Pasador valvula gatillo			Aro torico	
29	O-Ring	13302993	48	Kolbenring	14408618	67	Sicherungsring	14408556	89	Zylinderschraube	13303986
	O-ring			Piston ring			Circlip			Allan screw	
	Joint torique			Segment de piston			Clips			Vis cylindrique	
	Aro torico			Aro del piston			Aro de seguridad			Tornillo allen	
30	Druckfeder	13302994	49	Puffer	14408574	68	Vorschieber, kompl	14409578			
	Compression spring			Bumper			Pusher, cpl				
	Ressort à pression			Amortisseur			Chariot, cpl				
	Muelle de presión			Amortiguador			Empujador , cpl				
31	Zylinderschraube	13303014	50	Treiberführung	14408588	69	Vorschieberarretierung	14408403			
	Allan screw			Driver guide			Pusher stop				
	Vis cylindrique			Guide-marteau			Bouton d'arrêt pour chariot				
	Tornillo allen			Guia martillo			Boton parada empujador				
32	Schraubenabdeckung	13303015	51	Gehäuse	14408575	70	Endscheibe	14407752			
	Screw Cover			Body			End plate				
	VisCache			Corps			plateau de fin				
	Tornillo Tapa			Cuerpo			Arandela ce cierre				