

Typ 14/65-830C (Art.-Nr. 12000506)
Type

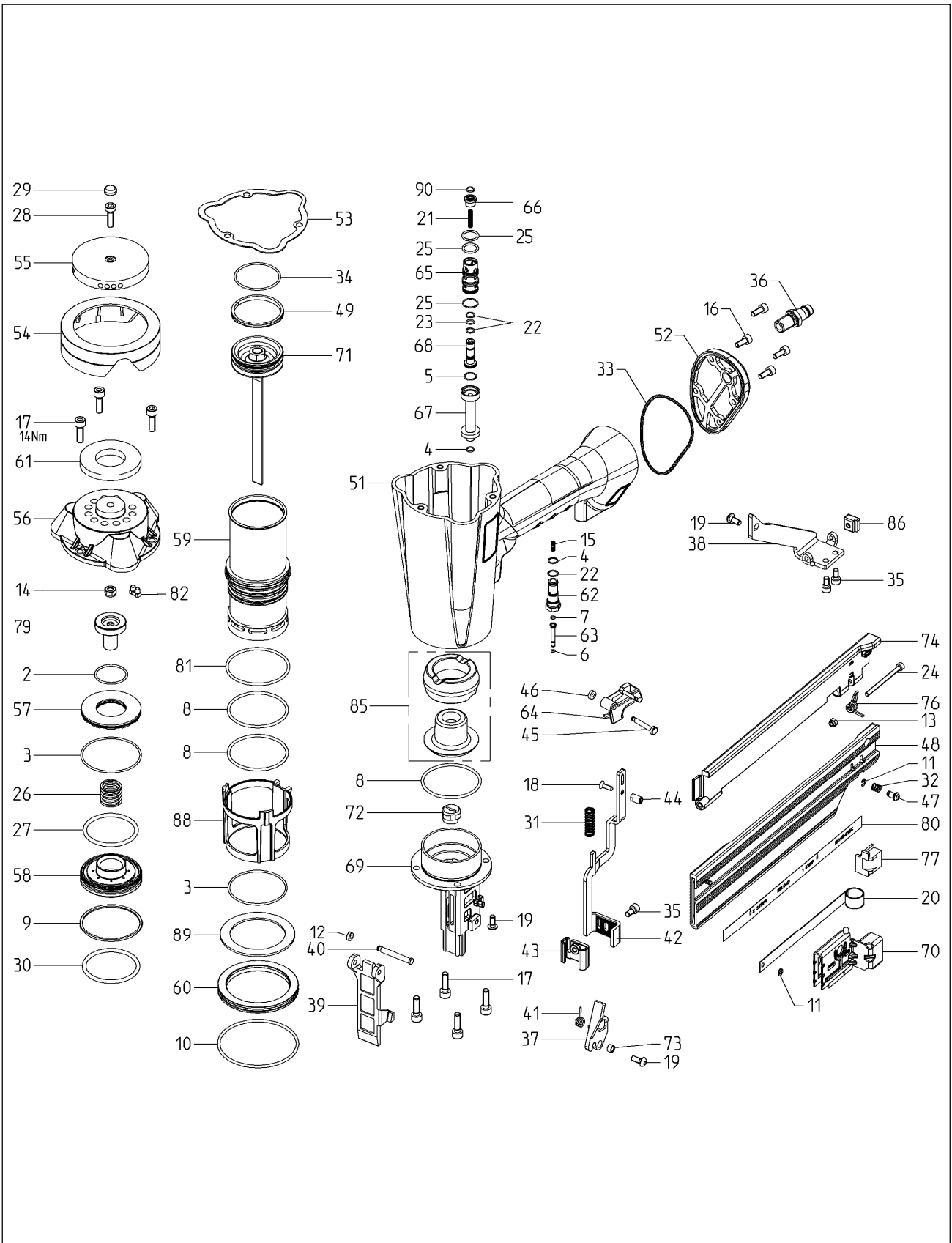

2	O-Ring	13300021	30	O-Ring	13303030	51	Gehäuse	14409221	69	Kopfstück	14409483
3	O-ring	13300029		O-ring			Body			Nose housing	
4	Joint torique	13300051		Joint torique			Corps			Tête	
5	Aro torico	13304007		Aro torico			Cuerpo			Testero	
6		13300060									
7		13300065	31	Druckfeder	13303060	52	Endscheibe	14407752	70	Vorschieber, kompl	14409578
8		13300095		Compression spring	13303063		Pièce queue			Pusher, cpl	
9		13300097		Ressort à pression			Pieza terminal			Chariot, cpl	
10		13303073		Muelle de presión			Pieza final			Empujador , cpl	
11	Sicherungsscheibe	13300347	33	O-Ring	13303128	53	Kappendichtung	14407753	71	Kolben, kompl	14408560
	Retaining washer			O-ring	13303065		Cap seal			Piston, cpl	
	Clips		34	Joint torique			Capuchon douille			Piston, cpl	
	Clip			Aro torico			Cabeza de fijacion			Piston, cpl	
12	Sicherungsring	13300355	35	Zylinderschraube	13303067	54	Kappenabdeckung	14407765	72	Treiberführung	14407878
	Circlip			Allan screw			Cover			Driver guide	
	Clips			Vis cylindrique			Cache			Guide-marteau	
	Aro de seguridad			Tornillo allen			Tapa			Guia martillo	
13	Sicherungsmutter	13300437	36	Stecknippel	14000244	55	Luftleitdeckel	14407754	73	Buchse	14404565
14	Safety nut	13300439		Plug-in nipple			Air deflector			Bushing	
	Ecrou de sûreté			Raccord enfichable			Couvercle de déflecteur			Douille	
	Tornillo de seguridad			Manguito enchufable			Tapa deflectora de aire			Casquillo	
15	Druckfeder	13303110	37	Hebel	14404564	56	Kappe	14408776	74	Abdeckschiene	14409055
	Compression spring			Lever			Cap			Cover	
	Ressort à pression			Levier			Capuchon			Rail de couverture	
	Muelle de presión			Palanca			Cabeza			Tapa cargador	
16	Zylinderschraube	13301117	38	Lasche	14407738	57	Kappenscheibe	14407755	76	Schenkelfeder	14404611
17	Allan screw	13301137		Hook plate			Cap disc			Leg spring	
	Vis cylindrique			Plaquette d'ancrage			Rondelle du capuchon			Ressort à branches	
	Tornillo allen			Placa con ganchos			Arandela de cabeza			Muelle en pata	
18	Senkschraube	13301273	39	Kopfstückklappe	14407739	58	Hauptventil	14408231	77	Rollfederführung	14404616
	Countersunk screw			Nose housing door			Main valve			Support for roller spring	
	Vis creuse fraisée			Clapet de la tête			Soupape principale			Plaquette pour ressort enroulé	
	Tornillo avellanado			Puerta testero			Valvula principal			Soporte para muelle en rollo	
19	Linsenschraube	13301352	40	Achse	14407740	59	Zylinder	14409210	79	Dämpfer	14414288
	Lens head screw			Pin			Cylinder			Damper	
	Vis creuse fraisée			Axe			Cylindre			Amortisseur	
	Tornillo cabeza de la lente			Eje			Cilindro			Amortiguador	
20	Rollfeder	13301614	41	Schenkelfeder	14408555	60	Zylinderring	14407758	80	Aufkleber Magazin	14407891
	Roller spring			Leg spring			Cylinder spacer			Magazine label	
	Ressort enroulé			Ressort à branches			Anneau de cylindre			Étiquette	
	Muelle espiral			Muelle en pata			Espaciador del cilindro			Étiquette	
21	Druckfeder	13301775	42	Auslösebügel	14407741	61	Schalldämpfer	14407760	81	O-Ring	13303074
	Compression spring			Safety yoke			Silencer			O-ring	
	Ressort à pression			Palpeur de sécurité			Amortisseur de bruit			Joint torique	
	Muelle de presión			Estribo de seguridad			Silenciador			Aro torico	
22	O-Ring	13302647	43	Auslöseschuh	14407742	62	Ventilbuchse	14407761	82	Stopfen	14408670
23	O-ring	13300007		Safety shoe			Valve bush			Post cap	
	Joint torique			Sabot de déclencheur			Douille de soupape			Capuchon	
	Aro torico			Pedel de seguridad			Casquillo valvula			Capuchon	
24	Zylinderschraube	13302942	44	Hülse	14407743	63	Schaltstift	14407762	85	Puffer	14409236
	Allan screw			Sleeve			Valve pin			Bumper	
	Vis cylindrique			Douille			Bouton de commande			Amortisseur	
	Tornillo allen			Adaptador			Pasador valvula			Amortiguador	
25	O-Ring	13302993	45	Ventilhebelstift	14407744	64	Ventilhebel, kompl.	14407946	86	Vorschieberanschlag	14409276
	O-ring			Trigger valve stem			Trigger, compl			Pusher stop	
	Joint torique			Axe de levier de détente			Levier de détente			Chariot butoir	
	Aro torico			Pasador valvula gatillo			Palanca valvula gatillo			Empujador tope	
26	Druckfeder	13302994	46	Sicherungsring	14408556	65	Steuerhülse	14413986	88	Zylinderabstützung	14413594
	Compression spring			Circlip			Socket			Cylinder spacer	
	Ressort à pression			Clips			Douille			Support de cylindre	
	Muelle de presión			Aro de seguridad			Casquillo			Soporte cilindro	
27	O-Ring	13303009	47	Vorschieberarretierung	14408403	66	Steuerbuchse	14413759	89	Dämpfer	14413789
	O-ring			Pusher stop			Valve bushing			Damper	
	Joint torique			Bouton d'arrêt pour chariot			Douille de soupape			Amortisseur	
	Aro torico			Boton parada empujador			Casquillo valvula			Amortiguador	
28	Zylinderschraube	13303014	48	Klammerträger	14407745	67	Zwischenhülse	14414632	90	O-Ring	13300057
	Allan screw			Staple carrier			Cylinder, intermediate valve			O-ring	
	Vis cylindrique			Support d'agrafes			Arbre intermédiaire			Joint torique	
	Tornillo allen			Cargador grapas			Valvula intermedio cilindro			Aro torico	
29	Schraubenabdeckung	13303015	49	Kolbenring	14408612	68	Steuerkolben	14413758		Piston	
	Screw Cover			Piston ring			Piston			Piston	
	VisCache			Segment de piston			Pistón			Pistón	
	Tornillo Tapa			Aro del piston							