

Typ
Type

95/16-418

(Art.-Nr. 12000060, Standardgerät / Basic model)

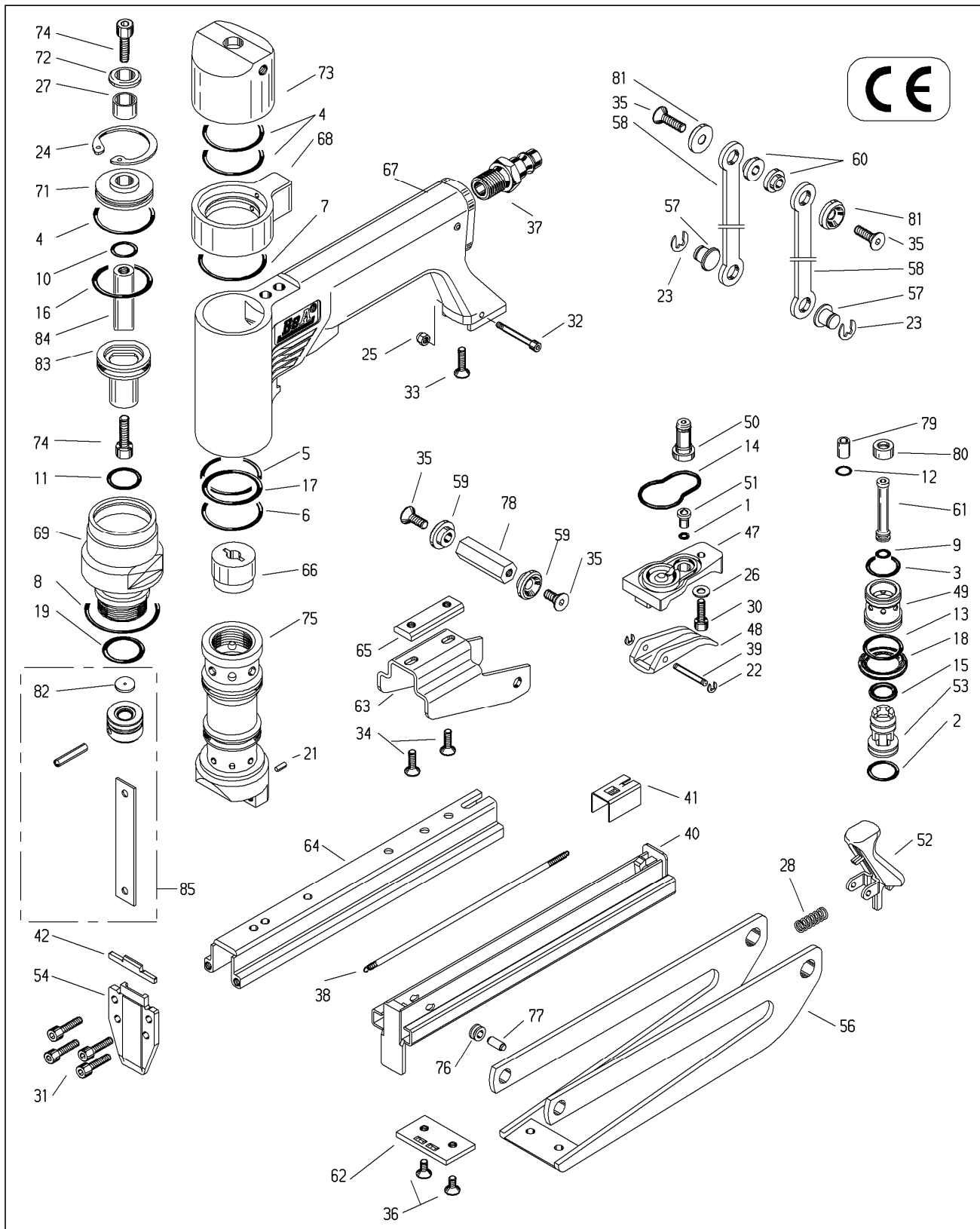

1	O-Ring	13300002	47	Ventilabdeckung	14403732	67	Gehäuse	14403890
2	O-ring	13300011		Valve cap			Body	
3	Joint torique	13300012		Capuchon de soupape			Corps	
4	Aro torico	13300020		Tapa valvula			Cuerpo	
5		13300021						
6		13300070	48	Auslöser	14403733	68	Adapter	14403891
7		13300023		Trigger			Adapter	
8		13300025		Levier de détente			Adapteur	
9		13300035		Gatillo de disparo			Adaptador	
10		13300042						
11		13300043	49	Ventilzylinder	14403734	69	Zylindergehäuse	14403894
12		13300051		Valve cylinder			Cylinder	
13		13300054		Cylindre de soupape			Cylindre	
14		13300070		Valvula cilindro			Cuerpo cilindro	
15		13300073						
16		13300079	50	Zwischenhülse	14403736	71	Deckel	14403898
17		13300080		Cylinder, intermediate valve			Cover plate	
18		13300111		Arbre intermédiaire			Plaque	
19		13300158		Valvula intermedio cilindro			Tapón	
22	Sicherungsscheibe	13300346	51	Schaltstift	14403738	72	Dämpfer	14403899
23	Circlip	13300349		Valve pin			Damper	
	Clips			Bouton de commande			Amortisseur	
	Clip			Pasador valvula			Regulador	
24	Sicherungsring	13300411	52	Sperrklinke	14403740	73	Kappe	14403901
	Circlip			Locking pawl			Cap	
	Clips			Cliquet			Capuchon	
	Aro de seguridad			Trinquete de cierre			Cabeza	
25	Sicherungsmutter	13300436	53	Ventilschaft	14403753	74	Hohlschraube	14403902
	Safety nut			Valve shaft			Hollow-core screw	
	Ecrou de sûreté			Corps de la soupape			Vis	
	Tornillo de seguridad			Vastago valvula			Tornillo hueco	
26	Scheibe	13300479	54	Werkzeug Teil 1	14403822	75	Zylinder	14403903
	Disc			Front nose			Cylinder	
	Rondelle			Plaque frontale			Cylindre	
	Arandela			Placa guia delantera			Cilindro	
27	Buchse	13300639	56	Zangenarm	14403878	76	Rolle	14403972
	Bushing			Jaw			Pulley	
	Douille			Levier à griffe			Rouleau	
	Casquillo			Mordaza			Rodillo	
28	Druckfeder	13301014	57	Gelenkzapfen	14403879	77	Achse	14403973
	Pressure spring			Bolt		78	Pin	14405196
	Ressort à pression			Boulon			Axe	
	Muelle de presion			Bulón			Eje	
30	Zylinderschraube	13301104	58	Zugstab	14403880	79	Hülse	14404160
31	Allen bolt	13302683		Linkage			Sleeve	
32	Vis cylindrique	14403739		Barre de traction			Douille	
	Tornillo allen			Barra de traccion			Adaptador	
33	Senkschraube	13302684	59	Lagerbuchse	14403881	80	Dichtring	14404166
34	Countersunk bolt	13301258		Bushing	14404168		Gasket	
35	Vis creuse fraisée	13301259	60	Douille			Joint plat	
36	Tornillo avellanado	13301264		Cojinete cilíndrico			Junta obturadora	
37	Anschlußnippel	14000244	61	Tülle	14403893	81	Scheibe	14404169
	Air hose connector			Socket			Disc	
	Embout de raccordement			Douille			Rondelle	
	Conector de aire manguera			Boquilla			Arandela	
38	Zugfeder	14400053	62	Matrize	14405195	82	Kolbendämpfer	14409148
	Tension spring			Matrice			Piston damper	
	Ressort de traction			Enclume			Amortisseur	
	Muelle de traccion			Matriz			Amortiguador	
39	Achse	14400118	63	Führungsprofil	14405200	83	Kolben	14412482
	Pin			Support			Piston	
	Axe			Support			Piston	
	Eje			Soporte guia			Piston	
40	Unterschieber	14403704	64	Abdeckschiene	14405197	84	Kolbenstange	14412483
	Back nose assembly			Cover			Piston shaft	
	Chargeur			Rail de couverture			Tige du piston	
	Guia			Tapa cargador			Vastago del piston	
41	Schubkasten	14403708	65	Gewindeleiste	14405199	85	Kolben, kompl.	14415334
	Feeder bar			Threaded rod			Piston, unit	
	Chariot			Bloque de serrage			Piston, complet	
	Barra cargador			Vastago roscado			Piston, cpl.	
42	Werkzeug Teil 2	14403711	66	Puffer	14403888			
	Back nose			Bumper				
	Plaque arrière			Amortisseur				
	Placa guia posterior			Amortiguador				